

23-350 EDV-NR.SA463
GEHAEUSE, MOTOR, SCHALTER, SCHNEIDKOPF

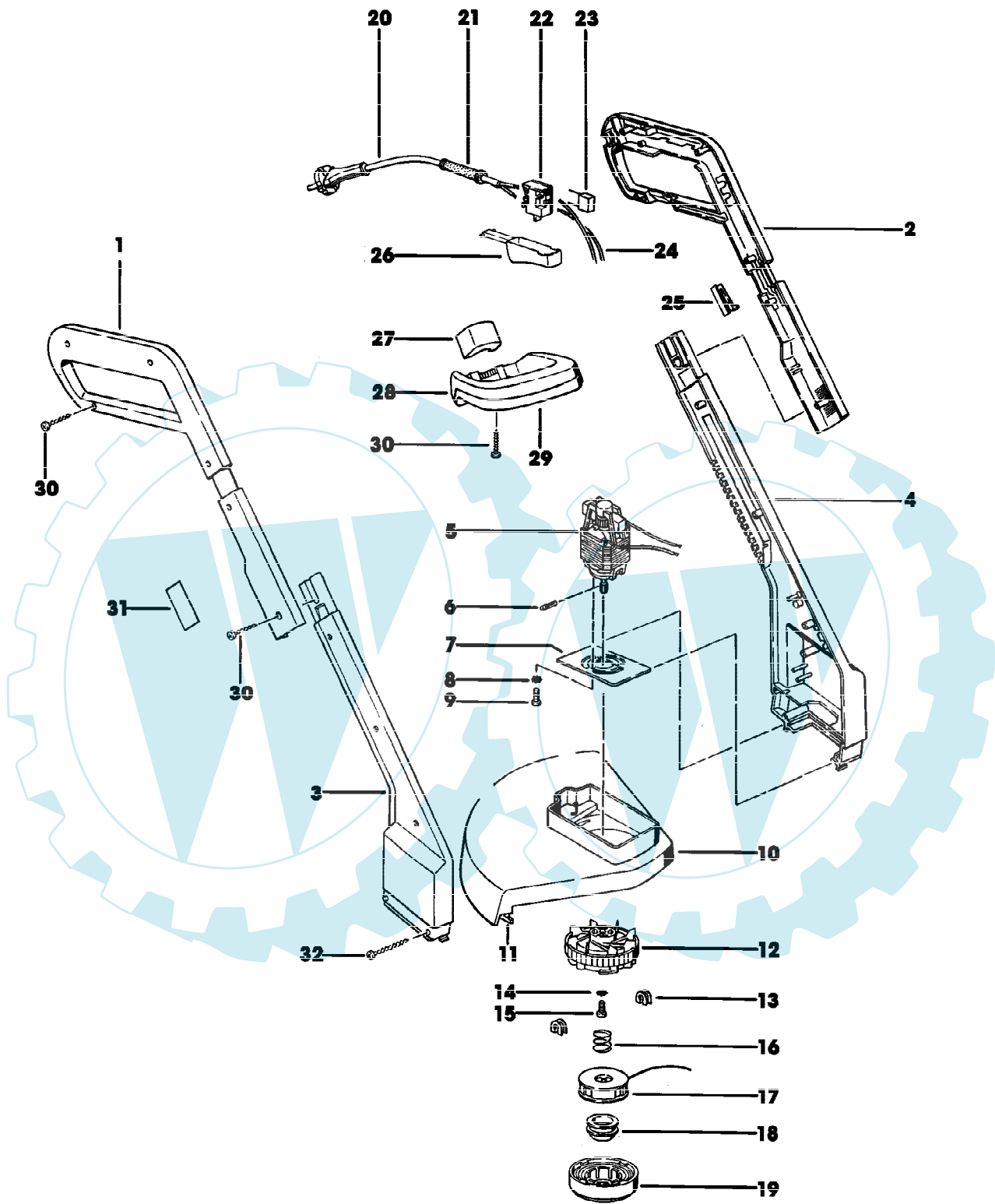

SA000879

23-350 EDV-NR.SA463
 GEHAEUSE, MOTOR, SCHALTER, SCHNEIDKOPF

Reihennummer	Artikelnummer	Menge	Description
1	SA34541	1	GRIFF * RH
2	SA34542	1	GRIFF * LH
3	SA34543	1	GEHAEUSE * RH
4	SA34544	1	GEHAEUSE * LH
5	SA34545	1	ELEKTROMOTOR 350 W
6	SA34547	1	SPANNSTIFT 3X12
7	SA34549	1	PLATTE
8	SA15230	3	FEDERRING (SUB FOR SA34550)
9	SA15541	3	SCHRAUBE * M4X10
10	SA34552	1	ABDECKUNG
11	SA34554	1	MESSER
12	SA34560	1	PLATTE
13	SA34562	2	OESE
14	SA34550	1	FEDERRING A4,3
15	SA34563	1	SCHRAUBE * M4X12
16	SA34564	1	FEDER
17	SA34501	1	SPULE *
18	SA34568	1	KNOPF
19	SA34569	1	DECKEL
20	SA34570	1	LEITUNG (SUB FOR SA17528)
21	SA34571	1	SCHLAUCHSCHUTZ
22	SA34572	1	SCHALTER
23	SA34573	1	KONDENSATOR *
24	SA34574	2	KABEL
25	SA34575	1	FEDER
26	SA34576	1	KONSOLE
27	SA34577	1	KLEMME
28	SA34834	1	GRIFF * UP (SUB FOR SA34578)
29	SA34579	1	GRIFF * LOW
30	SA34580	17	SCHRAUBE * 3,5X20
31	SA34581	2	AUFKL.SABO
32	SA34582	1	SCHRAUBE 4X40